

CJ Series

STAND POWER CJ(General Models)Series Valve Regulated Lead Acid batteries are designed with AGM(Absorbent Glass Mat) technology, high performance plates and electrolyte to gain extra power output for common power backup system applications widely used in the field of UPS, Emergency Lighting System.

Application

- Alarm System
- Cable Television
- Communication Equipment
- Control Equipment
- Security System
- Medical Equipment
- UPS
- Power tools
- Emergency Power System
- Toys

General Features

- Sealed and maintenance free operation.
- Non-Spillable construction design.
- ABS containers and covers(UL94HB, UL94V-0) optional.
- Safety valve installation for explosion proof.
- High quality and high reliability.
- Exceptional deep discharge recovery performance.
- Low self discharge characteristic.
- Flexibility design for multiple install positions.

Construction

- ComponentRaw material
- PositiveLead dioxide
- NegativeLead
- ContainerABS
- CoverABS
- SealantEpoxy Resin
- Safety valveEPDR
- TerminalCopper
- SeparatorFiber glass
- ElectrolyteSulfuric acid

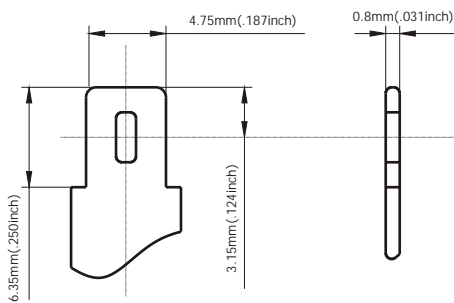

Terminal Dimensions

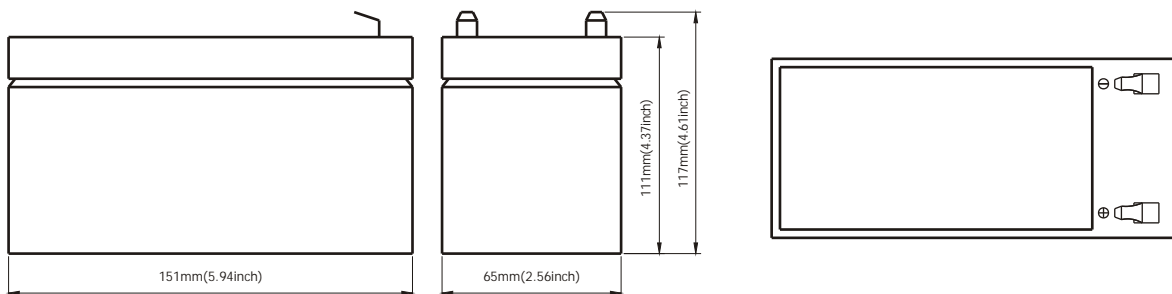

Battery Model	CJ 12-9			
Designed Floating Life	5 Years			
Capacity(25°C)	20HR(0.45A,1.75V)	10HR(0.85A,1.75V)	5HR(1.53A,1.75V)	1HR(5.85A,1.75V)
	9AH	8.5AH	7.65AH	5.85AH
Dimensions	Length	Width	Height	Total Height
	151mm(5.94inch)	65mm(2.56inch)	111mm(4.37inch)	117mm(4.61inch)
Approx. Weight	2.9Kg (6.39 lbs)			
Internal Resistance	Full charged at 25°C :0.02 Ohm			
Self Discharge	3% of capacity declined per month at (25°C)			
Capacity Affected by Temp.(20HR)	40°C	25°C	0°C	-15°C
	102%	100%	85%	65%
Charge Voltage(25°C)	Cycle use		Float use	
	14.4-14.8V(-30mV/ °C), max. Current: 2.7A		13.6-13.8(-20mV/ °C)	

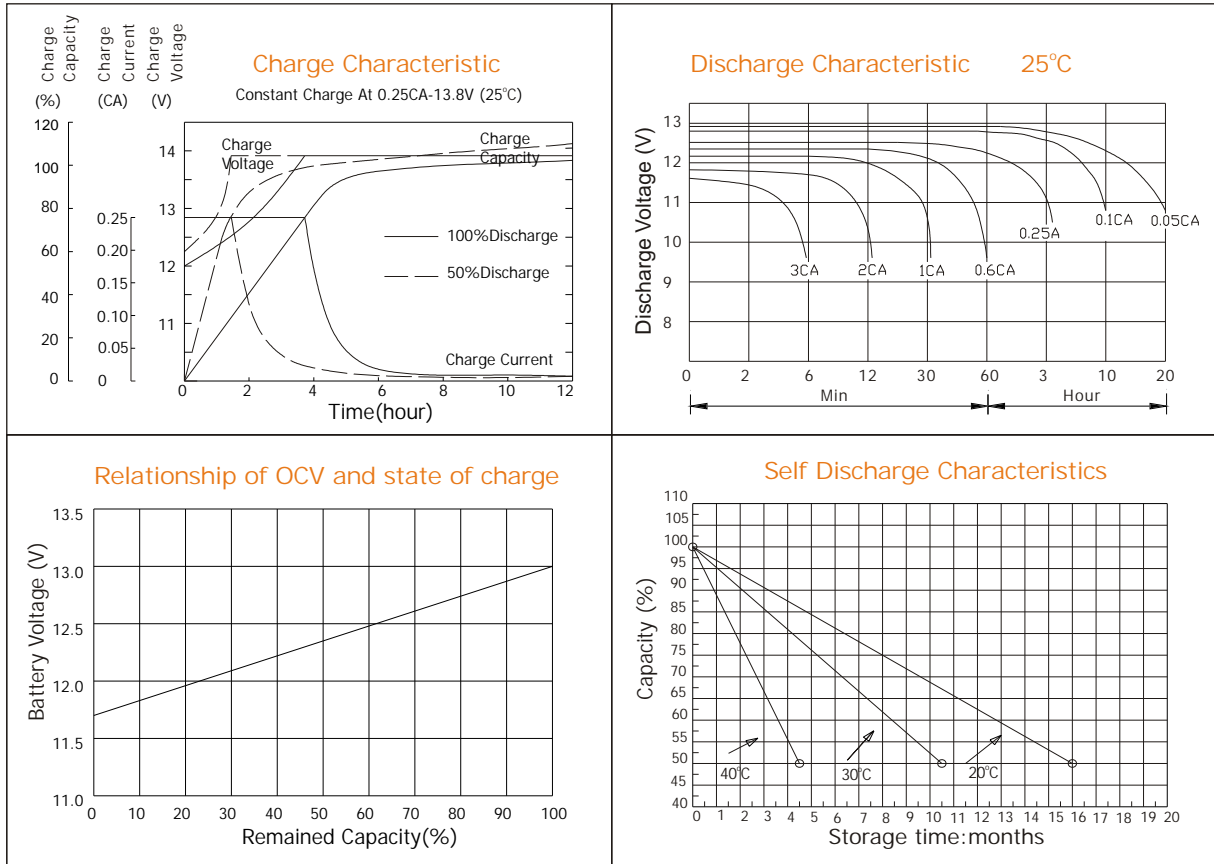

Constant current discharge ratings-amperes at 25°C

F. V/Time	5MIN	10MIN	15MIN	30MIN	1HR	3HR	5HR	10HR	20HR
1.60V	35.2	21.9	16.5	10.1	6.40	2.81	1.72	0.96	0.51
1.67V	33.0	20.8	15.9	9.63	6.31	2.70	1.68	0.95	0.49
1.70V	30.2	20.0	15.5	8.75	6.12	2.52	1.64	0.95	0.48
1.75V	29.6	19.4	15.0	8.31	5.83	2.44	1.61	0.93	0.47
1.80V	26.5	18.5	13.6	7.70	5.46	2.34	1.51	0.92	0.45
1.85V	23.4	17.6	12.3	7.09	5.09	2.26	1.42	0.91	0.44

Constant power discharge ratings-watts at 25°C

F. V/Time	5MIN	10MIN	15MIN	30MIN	1HR	3HR	5HR	10HR	20HR
1.60V	61.7	39.5	30.1	18.1	11.5	4.98	2.90	1.92	1.01
1.67V	59.5	38.5	29.8	17.8	11.5	4.82	2.89	1.91	0.97
1.70V	56.0	38.1	29.5	16.6	11.3	4.61	2.85	1.90	0.96
1.75V	56.4	38.0	29.3	16.1	11.1	4.50	2.83	1.87	0.94
1.80V	51.6	37.4	27.1	15.4	10.4	4.37	2.74	1.85	0.91
1.85V	46.8	35.5	24.6	14.4	9.80	4.24	2.65	1.82	0.88



STAND POWER INDUSTRIAL CO., LTD.
Room 26A-B, ShangBu Building, No.68, NanYuan Road, ShenZhen 518031 P.R.China.
Tel: (+86-755)83661105, 83661090, 83661091, 83661092 Fax: (+86-755)83661101
Website: www.standbattery.com E-mail: Sales@standbattery.com