

HIGH ENERGY SERIES

Nickel-Cadmium

VE D

With the VE series, Saft upgrades its standard technology : it boosts capacity by 10 to 15% without increasing volume, while at the same time maintaining performance levels.

The VE D cell offers significant capacity Gains for the same volume, high energy for applications requiring a higher operating time and good storage retention.

To meet customers requirements, Saft provides custom-designed and standardized battery packs.

For your battery design and system needs, please contact Saft's engineers.



Applications

- Professional electronics
- Cordless communication systems
- Medical equipment
- Lighting equipment

Main advantages

- High energy series giving a higher operating time
- Good storage retention
- Quick and fast charge
- Cycling application

Technology

- Sintered positive electrode
- Sintered negative electrode

Temperature range in discharge

-20°C to +60°C

Storage

Recommended: +5°C to +25°C

Relative humidity: 65 ± 5%

Data are given for single cell.

Please consult Saft for utilization of cell outside this specification.

Electrical characteristics

Nominal voltage (V)	1.2
IEC typical capacity (mAh) at C/5	5100
IEC minimum capacity (mAh) at C/5	4500
IEC designation	KRH 35/62
Impedance at 1000 Hz (mΩ)	2.6

Dimensions

Diameter (mm)	32.4 +/- 0.2
Height (mm)	58.8 +/- 0.2
Top projection (mm)	1.7 +/- 0.2
Top flat area diameter (mm)	9.8
Weight (g)	150

Dimensions are given for bare cells

Charge conditions

Rate	Time (h)	Temp. (°C)	Charge current (mA)
Fast	~1	+10 to +40	4500
Quick	6 to 7	+5 to +50	900
Standard	16	0 to +50	450
Permanent		0 to +50	<225
Trickle*		-20 to +50	110

End of charge cut-off is requested: -dV or dT°C/dt

* Trickle charge follows quick or fast charge

The maximum battery temperature recommended during charge is +45°C

Maximum discharge current

Continuous (A) at +20°C	31.5
Peak (A) at +20°C*	138

* Peak duration: 0.3 second - final discharge voltage 0.65 volt/cell



HIGH ENERGY SERIES

Nickel-Cadmium

VE D

Voltage in normal charge (current 0.1 C)

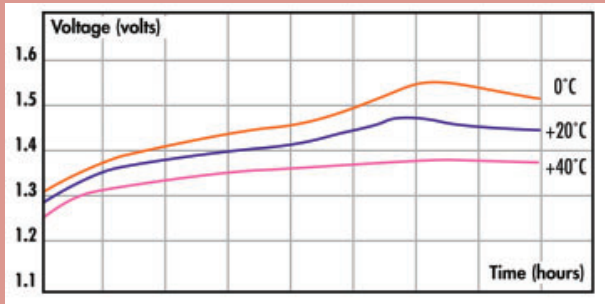

Voltage in quick charge (current 0.2 C)

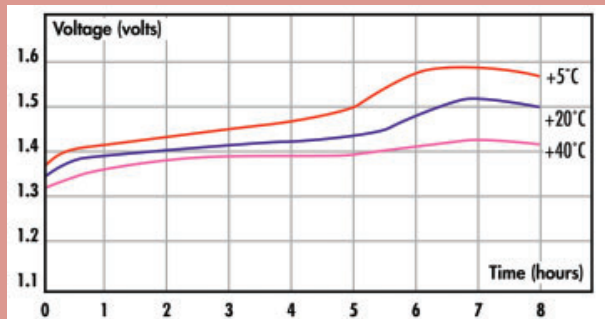

Voltage in discharge at +20°C

(after charge 0.1 C x 16 hours at +20°C)

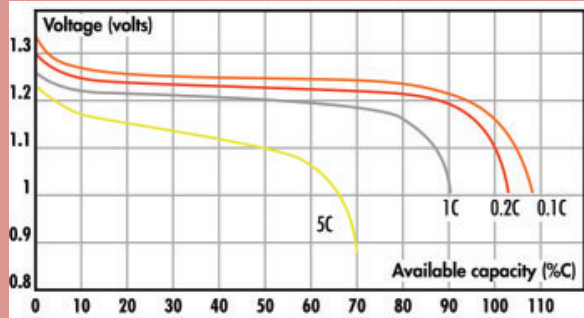

Available capacity (after charge 0.1 C x 16 hours at +20°C)

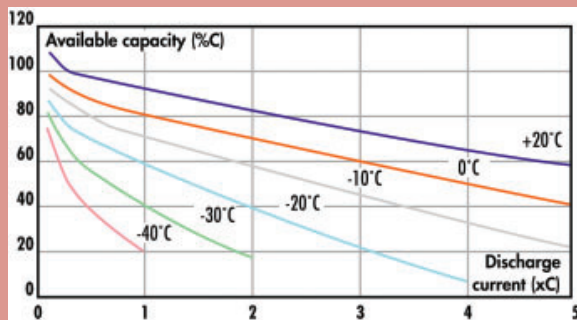

Typical performances

For graphs shown, C is the IEC₅ capacity.

Dimensions are in mm.

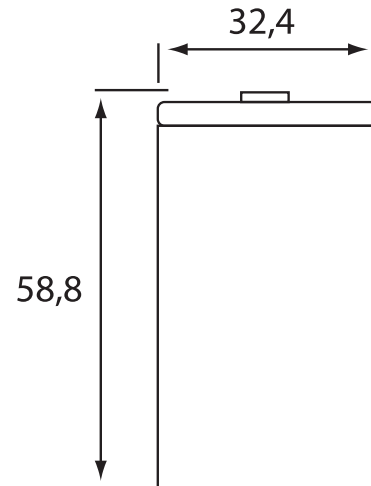

SAFT

Rechargeable Battery systems

12, rue Sadi Carnot
 93170 Bagnolet - France
 Phone: +33 (0)1 49 93 19 18
 Fax: +33 (0)1 49 93 19 68
 Email: rbs.info@saft.alcatel.fr
 DOC. N° 11074-2-0602
 Published by the Communication Department

www.saftbatteries.com

Data in this document are subject to change without notice and become contractual only after written confirmation by Saft.

